

FOR PLANNING PURPOSES ONLY AND ARE NOT TO BE USED FOR TENDER OR CONSTRUCTION

GENERAL NOTES

- DO NOT SCALE THIS DRAWING.
- CONTRACTOR TO CHECK ALL DIMENSIONS AND REPORT ALL ERRORS AND OMISSIONS TO THE ENGINEER.
- ANY DISCREPANCY TO BE REPORTED IMMEDIATELY TO THE ENGINEER.
- THIS DRAWING TO BE READ IN CONJUNCTION WITH ALL RELEVANT ARCHITECTS, SUBCONTRACTORS AND SPECIALISTS DRAWINGS AND SPECIFICATIONS.

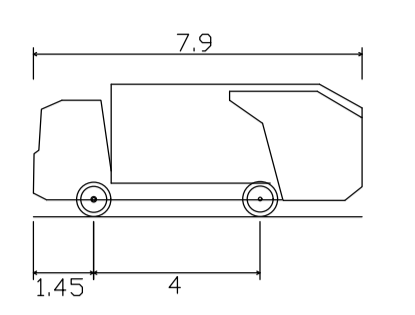

DB32 Refuse Vehicle	7.900m
Overall Length	2.400m
Overall Width	3.183m
Overall Body Height	0.388m
Min Body Ground Clearance	2.400m
Max Track Width	6.00s
Lock-to-lock time	9.625m
Curb to Curb Turning Radius	

- ACCESS ROAD GEOMETRY
- SHARED SURFACE ROAD GEOMETRY

- RET. WALL KEY
- 0.5-1M HIGH
 - 1 IN 3 BATTER TO EXISTING

B	BATTER TO THE SOUTH OF THE SITE OMITTED. RT WALL INTRODUCED.	DF	15.10.18
A	DRAWING AMENDED TO SUIT REVISED LAYOUT	DF	12.10.18
Rev.	Detail	By	Date

Reinforcement schedules nos.

Structural & Civil Engineering Consultants

First Floor
7 St James Crescent
Swansea
SA1 6DP

Telephone +44 1792 473 182
e-mail admin@cb3consult.co.uk
web www.cb3consult.co.uk

Client: TAI WALES & WEST HOUSING

Project: PROPOSED HOUSING DEVELOPMENT AT FORMER TOLL GATE INN ABERYSTWYTH

Drawing Title: HIGHWAY LAYOUT PLAN

PLANNING

Project No. C1244	Drawing No. C-SK02
Scales: 1:200	Date: 30.08.18
Drawn: DF	Checked: DF
Sheet Size: A1	Revision: B

© This drawing may not be copied without prior written permission